

# FOUR MILE SPECIAL SERVICE DISTRICT

363 W. Independence Blvd · Harrisville, Utah 84404 · 801-782-4100

## FOUR MILE SPECIAL SERVICE DISTRICT

March 11<sup>th</sup>, 2025

[Zoom Meeting Link](#)

Meeting ID: 844 9730 4721

Passcode: 574233

### 6:45 PM Four Mile Special Service District Board Meeting

1. **Call to Order**
2. **Consent Item**
  - a. Approval of meeting minutes for December 10<sup>th</sup>, 2024 as presented.
3. **Business Items**
  - a. Harrisville Fields Annexation Update. [Jennie Knight]
  - b. Discussion/possible action to adopt District Standards and Fee Schedule. [Jennie Knight]
4. **Board/Staff Follow-Up**
5. **Adjournment**

The foregoing Four Mile Special Service District agenda was posted and can be viewed at City Hall, on the City's website [www.cityofharrisville.com](http://www.cityofharrisville.com), and at the Utah Public Notice Website at <http://pmn.utah.gov>. Notice of this meeting has also been duly provided as required by law.

In accordance with the Americans with Disabilities Act, the City of Harrisville will make reasonable accommodations for participation in the meeting. Requests for assistance may be made by contacting the City Recorder at (801) 782-4100, at least three working days before the meeting.

Posted: By: Jack Fogal, City Recorder.

**MINUTES**  
**FOUR MILE SPECIAL SERVICE DISTRICT**  
**December 10, 2024**  
**363 West Independence Blvd**  
**Harrisville, UT 84404**

---

Minutes of a regular Four Mile Special Service District meeting held on December 10th, 2024 at 6:45 P.M. in the Harrisville City Council Chambers, 363 West Independence Blvd., Harrisville, UT.

**Present:** Chair Michelle Tait, Trustee Karen Fawcett, Trustee Grover Wilhelmsen, Trustee Blair Christensen, Trustee Max Jackson, Trustee Steve Weiss.

**Excused:**

**Staff:** Jennie Knight, City Administrator, Brody Flint, City Attorney, Justin Shinsel, Public Works Director, Jack Fogal, City Recorder, Mark Wilson, Chief of Police.

**Visitors:** Arnold Tait, Glade McCombs.

**1. Call to Order.**

Chair Tait called the meeting to order and welcomed all in attendance.

**2. Consent Items**

**a. Approval of The Meeting Minutes For November 12<sup>th</sup>, 2024 As Presented**

**Motion:** Trustee Wilhelmsen made a motion to approve the meeting minutes for November 12<sup>th</sup>, 2024 as presented, second by Trustee Christensen.

The vote on the motion was as follows:

Trustee Wilhelmsen, Yes  
Trustee Weiss, Yes  
Trustee Christensen, Yes  
Trustee Jackson, Yes  
Trustee Fawcett, Yes

The motion passed unanimously.

**3. Business Items.**

**a. Discussion/possible action to adopt Resolution 24-17; a resolution acting on a petition for annexation of certain real property in accordance with Title 17B Chapter 1 Part 4 *Utah Code Annotated, 1953 as amended.***

Jennie Knight explained this is the formal action to complete the annexation process for the Oak Hollow subdivision. We have not received comments or protests from the public. Staff is recommending annexation. Council Member Wilhelmsen inquired about the boundaries. Jennie Knight explained it goes from 700 North to Larsen Ln.

**Motion:** Trustee Wilhelmsen made a motion to adopt Resolution 24-17; a resolution acting on a petition for annexation of certain real property in accordance with Title 17B Chapter 1 Part 4 *Utah Code Annotated*, 1953 as amended, second by Trustee Weiss.

The vote on the motion was as follows:

Trustee Wilhelmsen, Yes  
Trustee Weiss, Yes  
Trustee Christensen, Yes  
Trustee Jackson, Yes  
Trustee Fawcett, Yes

The motion passed unanimously.

**4. Board/Staff Follow-Up**

Jennie Knight explained we will be bringing new standards and fee schedules before the Board in a few months.

**5. Adjournment**

Trustee Weiss motioned to adjourn the meeting, second by Trustee Christensen.

The vote on the motion was as follows:

Trustee Wilhelmsen, Yes  
Trustee Weiss, Yes  
Trustee Christensen, Yes  
Trustee Jackson, Yes  
Trustee Fawcett, Yes

The motion passed unanimously.

The meeting adjourned at 6:49 P.M.

---

**MICHELLE TAIT**  
Chair

**ATTEST:**

---

**Jack Fogal**  
City Recorder

Four-Mile Special Service District

# District Standards for Development, Design, & Construction



**DRAFT**

**March 2025**

Prepared by  
**JONES & ASSOCIATES**  
*Consulting Engineers*

DEVELOPMENT, DESIGN,  
AND CONSTRUCTION STANDARDS  
for  
FOUR-MILE SPECIAL SERVICE DISTRICT

**SUBMITTED & RECOMMENDED:**

\_\_\_\_\_  
District Engineer

\_\_\_\_\_  
Date

**APPROVED:**

\_\_\_\_\_  
Board Chairperson

\_\_\_\_\_  
Date

\_\_\_\_\_  
Director of Public Works

\_\_\_\_\_  
Date

\_\_\_\_\_  
Attest, City Recorder

\_\_\_\_\_  
Date

**TABLE OF CONTENTS**

**SECTION 1 GENERAL..... 1**

- 1.01 Conformance with Federal, State, and Local Laws ..... 1
- 1.02 Definitions..... 1
- 1.03 Acronyms ..... 1
- 1.04 Variances from the Public Works Standards..... 2

**SECTION 2 DEVELOPMENT STANDARDS ..... 3**

- 2.01 Approval Procedure ..... 3
- 2.02 Developer Responsibilities..... 3
- 2.03 Geotechnical Investigation ..... 4

**SECTION 3 DESIGN STANDARDS..... 5**

- 3.01 Required Improvements ..... 5
- 3.02 Improvement Plans..... 5
- 3.03 Secondary Water Design..... 6

**SECTION 4 CONSTRUCTION STANDARDS..... 8**

- 4.01 General..... 8
- 4.02 Pre-Construction Conference ..... 12
- 4.03 Construction..... 12
- 4.04 Miscellaneous ..... 14

**SECTION 5 TECHNICAL SPECIFICATIONS ..... 16**

- 5.01 Technical Specifications for Four-Mile Special Service District..... 16
- 5.02 Order of Precedence..... 16

**SECTION 6 STANDARD DRAWINGS, PLANS, AND DETAILS..... 17**

- 6.01 Standard Drawings, Plans, and Details for Fourmile Special Service District ..... 17
- 6.02 Order of Precedence..... 17

**APPENDICES**

- A FOUR-MILE SPECIAL SERVICE DISTRICT STANDARD DRAWINGS**

## SECTION 1 GENERAL

### 1.01 Conformance with Federal, State, and Local Laws

**Nothing in this document shall relieve the Developer, Engineer, or Contractor from abiding by any and all Federal, State, and local laws.**

### 1.02 Definitions

- A. Contractor – The individual, firm, co-partnership, or corporation, and his, their, or its heirs, executors, administrators, successors, and assigns, or the lawful agent of any such individual firm, partnership, covenantor, or corporation, or his, their, or its surety under the contract bond, constituting one of the principals to the contract and undertaking to perform the Work.
- B. Drawings – The District-approved construction drawings, the Four-Mile Special Service District Standard Drawings, and/or the Manual of Standard Drawings, as applicable.
- C. Developer – The person or company sponsoring construction of the improvements.
- D. Development – The subject subdivision, minor subdivision, or building.
- E. District – Four-Mile Special Service District
- F. Improvements – See “Work.”
- G. Improvement Plans – See “Drawings.”
- H. Inspector – The authorized representative of the District or District Engineer assigned to make all necessary inspections of the Work performed or being performed, or of materials furnished or being furnished by the Contractor.
- I. Standards – When “Standards” is written, it shall be as if “Four-Mile Special Service District Development, Design, and Construction Standards” is written.
- J. Work – All types of work necessary to provide safe access and utility service to and within proposed subdivision or site, including, but not limited to, site grading, utility installation, and street construction. Work includes all labor, services, and documentation necessary to produce such construction; furnishing, installing, and incorporating all materials and equipment into such construction; and may include related services such as testing, start-up, and commissioning.<sup>1</sup>

### 1.03 Acronyms

- A. APWA – American Public Works Association
- B. BMP – Best Management Practice
- C. DWQ – Division of Water Quality
- D. DWRi – Division of Water Rights
- E. HOA – Homeowners’ Association

---

<sup>1</sup> From EJCDC® C-700, Standard General Conditions of the Construction Contract.

- F. SSD – Special Service District
- G. PVC – Polyvinylchloride Pipe
- H. RCP – Reinforced Concrete Pipe
- I. UAC – Utah Administrative Code
- J. UDEQ – Utah Department of Environmental Quality
- K. USACE – United States Army Corps of Engineers

**1.04 Variances from the Public Works Standards**

- A. When a Developer believes that meeting a specific requirement contained within the current edition of the Four-Mile Special Service District Standards is technically infeasible, Developer may make application to the Director of Public Works or a Designee (Director) for a variance from the Standards. This application shall include technical reasoning for the proposed variance along with a proposed solution. The Director shall assess whether the request meets the goals and requirement of the Standards without unduly jeopardizing the public’s interest. Upon review of the application, the Director may grant or deny the variance from the Standards.



---

## SECTION 2 DEVELOPMENT STANDARDS

### 2.01 Approval Procedure

- A. The purpose of the Fourmile Special Service District is to provide pressurized secondary water in locations with Harrisville City where pressurized secondary system is unavailable. If it is feasible to connect to an existing secondary water system from another provider (Pineview Water Systems), it is the responsibility of the Developer to connect to their system and follow all of their inclusion and design requirements
- B. In areas that cannot be served secondary water by Pineview Water Systems, the development may petition the City to be annexed into the Four-Mile Special District (District). To be annexed into the District, the development must have adequate water shares and demonstrate the ability to create a viable pressurized secondary water system approved by the City Engineer and per the requirements of this section.

### 2.02 Developer Responsibilities

- A. The Developer shall prepare and submit an annexation plat to the District of the area to be serviced by the District. The District shall review the plat and consider the annexation. If approved the annexation plat shall be filed with the State and recorded at the County.
- B. The Developer and their Engineer shall be responsible to design a viable pressurized secondary water system per the requirements of this section. A secondary water design report shall be submitted to the District Engineer for review and approval. The secondary water improvements shall be included in the subdivision improvement drawings and approved by the District and Harrisville City.
- C. Permits and Approvals
  - 1. Developer is responsible for obtaining all necessary permits and approvals for the construction of the Improvements. Copies of all applications and approved permits shall be submitted to the City. Agencies/permits that may be required include, but are not limited to:
    - a. UPDES NOI and NOT
    - b. DWRi Stream Alteration
    - c. DWRi Dam Safety
    - d. EPA 404 Wetlands
    - e. FEMA LOMA and/or LOMR
    - f. UDOT
    - g. UTA or UPRR
    - h. Others as applicable
- D. Improvements

1. Survey and Mapping of New Improvements – Developer shall reimburse District for time spent surveying in locations of new improvements, including but not limited to manholes, valves, meters, pumps, and adding such improvements to the District maps.

**2.03 Geotechnical Investigation**

- A. A geotechnical investigation should be conducted for all new secondary water ponds.
- B. The geotechnical investigation should be complete in nature, and its findings shall be summarized in a Geotechnical Report. The Geotechnical Report shall be signed and sealed by a licensed Professional Engineer with expertise in the field of geotechnical engineering.

---

## SECTION 3 DESIGN STANDARDS

### 3.01 Required Improvements

- A. See also Section 5 – Standard Specifications and Section 6 – Standard Drawings, Plans, and Details of this document for additional information.

### 3.02 Improvement Plans

- A. Complete and detailed, and signed and sealed (in accordance with Utah Code 58-22-602) construction plans and drawings of improvements shall be submitted to the District for review prior to receiving final approval and prior to commencing construction. No construction shall begin until plans have been checked and approved by the District Engineer, final approval is granted by the City’s Administrative Land Use Authority, and a pre-construction meeting is held with the City.
- B. The following instructions are for the purpose of standardizing the preparation of drawings to obtain uniformity in appearance, clarity, size, and style. The plans and designs shall meet the standards defined in the specifications and drawings hereinafter outlined. The minimum information required on the drawings for improvements is as follows:
  - 1. All drawings and/or prints shall be clear and legible and conform to industry standard engineering and drafting practices.
  - 2. Drawings shall be legible and to a common scale when printed on 11”x17” paper.
  - 3. All wet utilities (water, sewer, storm drain, secondary, irrigation) shall be shown in plan and profiles views.
  - 4. Each set of plans shall be accompanied by a separate sheet of details for special structures which are to be constructed and are not covered by the District Standards. All structures shall be designed in accordance with the minimum District Standards and approved by the District Engineer.
  - 5. Separate drawings of elements of the District Standards shall not be required to be redrawn and submitted with the construction drawings unless specific deviations from the standards are requested for approval; however, the construction drawings shall refer to the specific items of the Standards that are to be incorporated into the Work.
  - 6. The plan and profile construction plans shall be submitted in portable document format (“pdf”). Upon approval, the developer’s engineer shall provide the District Engineer with electronic files of the final plat and improvement plans in AutoCAD or other District Engineer approved format. A hard copy of the accepted construction plans bearing the signature of the District Engineer shall be kept available at the construction site. Prior to final acceptance by the District, the developer, developer’s representative, contractor, or project engineer shall submit to the District Engineer a set of "as built" drawings for permanent District file record.
- C.

**3.03 Secondary Water Design**

- A. Certificates of water shares equal to 4.0 acre-feet of water for each irrigable acre must be deeded with the recordation of the Final Plat to the District.
- B. Ownership of the system shall be deeded to the District with the Final Plat dedication. Ownership of the District's portion of the system terminates at the meter.
- C. The water source must be piped through the development and improvements made to ensure that water will be able to reach the reservoir from the source. If water is dependent upon a particular share to be received at a particular time, then electronic actuators and gates will be required to receive the water without the employ of a person to manually open a gate.
- D. Adequate flow to have adequate storage for pressure irrigation between water turns must be obtained from the source. As a minimum, the average flow of 7 gallons per minute (gpm) per irrigable acre is required. This equates to 0.016 cfs/irrigable acre or 5.65 Ac-ft/yr/irrigable acre (183 days per year). Peak instantaneous flow calculations shall be used for pump sizing and distribution pipes.
- E. Reservoirs must be sized to hold a minimum of one-week supply of water for the entire system at build out. As a minimum, 1 ac-ft of storage is required for 50 acres of irrigable land per day. Unless approved by the District Engineer, secondary water shall be separated from storm drain water. Consideration for evaporation (0.33 in/day) and percolation must be taken in sizing storage facilities.
  - 1. 6-foot-tall chain link fence with a minimum of 15 feet between the fence and the perimeter for maintenance vehicles is required.
  - 2. Reservoirs shall be clay-lined to inhibit percolation and infiltration. Corners should be rounded to avoid stress concentrations in the event of future concrete lining.
  - 3. Maximum slope of the basins shall be 2 feet horizontal to 1 foot vertical.
  - 4. Reservoirs shall not exceed 12 feet deep and must be able to be drained. If the bottom of the reservoir is within 1 foot of the highest estimated groundwater level, then the pond shall be lined with an impermeable liner and land drain system shall be installed around the perimeter of the pond per geotechnical recommendations.
  - 5. All grates and screens must be hot dip galvanized to avoid corrosion.
  - 6. The top of the embankment in all areas shall be 1 foot above the high-water mark.
  - 7. The surface area around the basin shall be covered with weed barrier fabric and 2" minus gravel (4" thick).
  - 8. If a raised embankment is constructed for the reservoir (constructed with granular materials), it shall be provided with a minimum of 6" of clay cover on the inside of the berm to prevent water passage through the soil as well as the clay lining.

9. If the basin is constructed primarily by excavation, then it may be necessary to provide an impermeable line and land drain system when constructed in the proximity of basements or other below grade structures as determined by a geotechnical evaluation.
- F. Systems pressurized by gravity are always desirable, however pumps may be used where necessary. Pumps, which shall directly pressurize the system, shall be Variable Frequency Drive (VFD) pumps with redundancy designed for meeting the peak instantaneous flows and shall follow the details outlined in the Standard Drawings. The hydraulics of the system should be set for a peak instantaneous flow equal to the following formula:
1.  $Q = U * 180 * N^{0.55}$ 
    - a. Q is the instantaneous flow rate in gpm
    - b. U is the usage factor (no less than 60% or 0.6)
    - c. N is the total number of irrigable acres
  2. In no case shall the peak instantaneous flow rate per irrigable acre be less than 8 gpm. Pressures should be designed between 60 psi (139' TDH) and 100 psi (230' TDH). Pump curves shall be submitted to the District along with the Operation and Maintenance Manual for the pump. Velocities in the pipes shall not exceed 4 feet per second during peak instantaneous demand. A minimum of 2 pumps must be installed to accommodate redundancy and low flows. A VFD system shall be included to handle the above flows and pressures.
- G. Distribution systems shall be sized in accordance with the above criteria to meet flows, quality and quantities as given in the above criteria.
1. Piping: 4" through 24" – AWWA C900 DR 18, purple
  2. Service lateral must be provided to each lot. Single laterals shall be 1" and double laterals shall be 1 ½" with separate shut off valves. Lateral material shall be Polyethylene (PE) 200 psi copper tubing size (CTS).
  3. Meter and meter box assembly are required on all laterals (see drawings).
  4. Drains must be installed to a storm drain at low spots in the system.
  5. Air/vacuum valves shall be installed at not more than 1,000 foot spacing.

---

## SECTION 4 CONSTRUCTION STANDARDS

### 4.01 General

#### A. General Conditions

1. Permit/License: When the work is in progress, Contractor shall have at the work site a copy of the permit and their contractor's license number.
2. Private Access: Temporary all-weather roadways, driveways, walks, and rights-of-way for vehicles and pedestrians shall be constructed and continuously maintained where required.
3. Street Excavation in Winter: Excavation of City streets during the winter months (herein defined as November 15 to April 1) will be allowed only if the work is a new service connection, required maintenance or emergency, or otherwise approved by the Public Works Department. Permanent patching of City streets excavated in the winter may be delayed until April 1 with the following provisions: Within five (5) working days from the completion of the excavation, the permittee provides/maintains a 1-1/2" thick temporary winter asphalt surface until such time as the permanent asphalt surface is installed; the permittee shall provide/maintain a temporary untreated base course surface until such time as the temporary winter asphalt surface is installed. These provisions apply regardless of whether the permittee or City crews are performing the permanent resurfacing.
4. Street Excavation in Summer: Excavation of City streets during the summer months is herein defined as April 1 to November 15. Permanent hot asphalt patching of City streets in the summer shall be within five (5) days from the completion of the excavation. The permittee shall provide/maintain a temporary untreated base course surface until such time as the permanent hot asphalt patch surface is installed.
5. Existing Utilities: The contractor shall use extreme caution to avoid a conflict, contact, or damage to existing utilities, such as power lines, sewer lines, storm drains, streetlights, telephone lines, cable television lines, water lines, gas lines, poles, or other appurtenances during the course of construction of this project. Any such conflict, contact, or damage shall be immediately communicated to said utility company and the Public Works Department. All projects shall be "Blue Staked" prior to construction.
6. Preconstruction Pictures: The permittee shall secure pictures of the conditions of the existing public way improvements such as curbing, sidewalk, landscaping, asphalt surfaces, etc. In the event that public way improvements are damaged and no pictures were taken, the Public Works Department will assume the correction of the damage is the responsibility of the permittee.

#### B. Licensing

1. Contractor (including all sub-contractors) must be licensed with the State of Utah: It is the policy of Harrisville City that contractors desiring to perform work in the City's public way

shall be properly licensed in the State of Utah. The acceptable licenses shall be in accordance with UAC R156-55a-301, as amended.

C. Permits

Developer/Contractor is responsible for obtaining all necessary permits for the construction of the improvements prior to commencement of said improvements. Agencies/permits required may include, but are not limited to:

1. City Excavation

- a. Harrisville City's Department of Public Works issues permits to control any excavation and construction operations in the public right-of-way. All contractors, sub-contractors, and utility companies proposing to construct, repair, or replace any facility within the public right-of-way shall contact the Harrisville City Public Works Department and complete all permit requirements prior to commencing proposed work. See Title 7 of the City Code.
- b. Work by utility companies and contractors in constructing facilities in new subdivision streets shall be required to obtain an encroachment permit from the City and will be subject to City inspection and compliance with all requirements.
- c. Emergency Work
  - (i) Maintenance of pipelines or facilities in the public way may proceed without a permit when emergency circumstances demand the work be done immediately provided a permit could not reasonably and practicably have been obtained beforehand.
  - (ii) In the event that emergency work commences on or within any public way of the City, the Public Works Department shall be notified within one-half hour when the work commences or as soon as possible from the time the work is commenced. Contact shall be made to the City's "on call" personnel. If emergency work is commenced during off business hours, the Public Works Department will be notified within one (1) hour of the start of work on the first regular business day of which City offices are open after such work commences, and, at the discretion of the Public Works Department, a permit may be issued which shall be retroactive to the date when the work was begun. Before commencing the emergency work, all necessary safety precautions for the protection of the public and the direction and control of traffic shall be taken. None of the provisions of these regulations are waived for emergency situations except for the prior permit requirement.
- d. Enforcement: Violators of these regulations of working within the Public Way shall be subject to the provisions of the applicable Harrisville City Ordinances.
- e. Revocation of Permit Waivers: "Permit Waivers" shall be revoked by the Public Works Department if the work is found to be defective or requires action or supplemental

inspection by the Public Works Department. In the revocation proceedings, the Public Works Department shall serve written notice which defines the problems encountered and the time (at least one day) the permittee has to correct the problem. If the work is not satisfactorily completed within the time specified, the "Permit Waiver" shall be revoked. The permittee shall be required to secure a Fee Permit before proceeding to complete the work.

- f. Completion by City, Liability for Costs: If the work is unduly delayed by the permittee, or if the public interests so demand, the Public Works Department shall have authority to complete the permit work. The Public Works Department shall do the work only after written notice has been given to the permittee, and the permittee fails to respond to the Public Works Department's request. The actual cost of such work incurred by the City including a fifteen percent (15%) overhead charge shall be paid by the permittee.
2. USACE/DWRi Stream Alteration
  3. UPDES
  4. Harrisville City Stormwater Construction Activity Permit
  5. Dam Safety (DWRi)
  6. UPRR Railroad Encroachment
  7. UTA Encroachment
  8. UDOT
  9. Weber County Surveyor's Monument
- D. Excavation Operations
1. Blue Stakes: Before commencing excavation operations, the permittee shall call "Blue Stakes" at 1-800-662-4111 or 811.
  2. Traffic Control Devices: Traffic control devices such as construction signs, barricades, and cones must be in place before excavation begins.
  3. Protection of Paved Surfaces: To avoid unnecessary damage to paved surfaces, backhoes, outriggers, tracked equipment, or any other construction equipment that may prove damaging to asphalt shall use rubber cleats or paving pads when operating on or crossing said surfaces.
  4. Open Trench Limits: Open trenches will be limited to one block at a time or 660 feet, whichever is less.
  5. Public Road Closure: No public roads shall be closed without prior written approval from Harrisville City. In the event of a planned road closure, Contractor shall notify the City, Public Works Department, Fire Department, emergency services dispatch, US Postal Service, Weber School District, and Utah Transit Authority (UTA) a minimum of 24 hours prior to the



closure. In the case of an emergency, the above listed agencies will soon be notified at the soonest possible time.

6. Sidewalk Closure: When it is permitted to close the sidewalk, flashing barricades and “Sidewalk Closed” signs must be placed on the sidewalk immediately adjacent to the work area. “Sidewalk Closed Ahead, Cross Here” signs must be placed at the closest adjacent sidewalks, intersections, or alternate routes to warn pedestrians of the closing so they may safely access the alternate route.

E. Environmental Controls

1. Dust and Debris: The permittee or contractor shall keep dust and debris controlled at the work site at all times. If necessary, a container shall be provided for debris and dusty areas shall be wet down. The permittee or contractor shall be responsible for the cleanup of mud or debris from public roads deposited by vehicles or construction equipment exiting the work site. The City reserves the right to shut down the work or issue a citation if dust is not controlled.
2. Noise: The permittee or contractor shall keep neighborhood free of noise nuisance in accordance with Title 11.20.190 - Performance Standards of the City Ordinances.

- F. Cleanup: The permittee or contractor shall remove all equipment, material, barricades, and similar items from the right-of-way. Areas used for storage of excavated material will be smoothed and returned to their original contour. Vacuum sweeping or hand sweeping shall be required when the City determines cleaning equipment is ineffective.

- G. Storm Water: All Contractors working within the boundaries of Harrisville City shall conform to all requirements and regulations as outlined by the Harrisville City Storm Water Management Plan. Copies of the plan are available in the Harrisville City Offices.

H. Fencing and Signs

1. Fencing and barricade equipment shall conform to MUTCD standards. Fencing shall also conform to the following:
  - a. No advertisements shall be placed on barricades or construction signs.
  - b. Fencing and associated signs shall be removed and areas where signs are placed shall be restored to the pre-construction condition following construction.
2. Fencing (6' chain-link panels) shall be placed around all excavation pits adjoining pedestrian accesses traveled by the public. No construction activity (excavations, etc.) which may be of any risk to public safety shall remain unattended overnight.
3. All projects abutting the public rights of way shall be fenced.
4. Fences will be required on the perimeter of each new Subdivision where the property abuts an open canal, stream or river, or commercial or industrial zoned or used property or other dissimilar use.

5. Fences will be a minimum of six feet (6') high and of a type as approved by the Administrative Land Use Authority.
6. Fabric, slats, and other types of plastic materials will not be permitted on the fence.

**4.02 Pre-Construction Conference**

- A. The preconstruction conference shall not be held until the City's Administrative Land Use Authority has approved and signed the construction plans.
- B. A preconstruction conference shall be held before any excavation or other work is begun in the subdivision or Project. The secondary water improvements will be discussed in this meeting along with the other subdivision improvements. The meeting will include:
  1. City/District Engineer
  2. Developer or Project Manager
  3. Subdivision or Project Engineer
  4. All contractors and subcontractors involved with installing the subdivision or project improvements
  5. Representatives of affected Harrisville City and Fourmile SSD Departments.
  6. Representatives of local utility companies as may be required by Harrisville City.
- C. Items pertaining to the construction and inspection of the subdivision or Project improvements will be discussed.

**4.03 Construction**

- A. Specifications
  1. Contractor shall be responsible for constructing all improvements in accordance with the Technical Specifications, per Section 5 of this document.
  2. No deviations will be allowed unless reviewed and authorized by the District on a case-by-case basis.
- B. Plans and Details
  1. Contractor shall be responsible for constructing all improvements in accordance with the Drawings, Plans, and Details, per Section 6 of this document.
  2. No deviation will be allowed unless reviewed and authorized by the District on a case-by-case basis.
  3. If as-built conditions of the improvements are found to be out of compliance with the approved improvement plans and tolerances contained in these Standards, it shall be the contractor's responsibility to remove those improvements and replace them with improvements that comply with the approved improvement plans and are within the given

tolerances. Adjacent improvements may also require replacement to bring all improvements into compliance.

C. Sequence/Timing

1. All underground utility work shall be completed prior to placement and compaction of the roadway base course. Utilities, including service lines, not installed prior to roadway construction shall be bored as approved by the Director of Public Works.
2. All concrete collars shall be installed within fourteen (14) days of asphalt placement.

D. Inspection

1. All construction work involving the installation of improvements in the subdivision or project shall be subject to inspection by the City. It shall be the responsibility of the person responsible for construction to insure that inspections take place where and when required. Certain types of construction shall have continuous inspection, while others may have only periodic inspections.

E. Requests for Inspections

1. Requests for inspections shall be made to the Public Works Department by the person responsible for the construction.
2. Requests for inspection on work requiring continuous inspection shall be made three (3) working days prior to the commencing of the work.
3. Notice shall also be given one (1) day in advance of the starting of work requiring periodic inspection, unless specific approval is given otherwise by the City and District.

F. Continuous inspection

1. May be required on (but not limited to) the following types of work:
  - a. Laying of sewer pipe, irrigation pipe, drainage pipe, water mains, water service laterals and testing.
2. On construction requiring continuous inspection, no work shall be done except in the presence or by permission of the District Engineer or authorized city representative.

G. Periodic inspections

1. Shall be required on (but not limited to) the following types of work:
  - a. Excavations for structures
  - b. Trenches for laying pipe

H. Substantial and Final Completion Inspections

1. A substantial completion inspection shall be requested by the Contractor and made by the City and District Engineer or authorized representative after all construction work is completed. Any faulty or defective work shall be corrected by the persons responsible for

- the work within a period of thirty (30) days of the date of the City and District Engineer's or authorized representative's Punchlist defining the faulty or defective work.
2. A final completion inspection shall be requested by the Contractor and made by the City and District Engineer or authorized representative after all faulty and defective work has been corrected.
- I. Testing
1. Development Projects
    - a. Developer/Contractor shall select, hire, and pay a City-approved qualified testing firm.
    - b. Developer/Contractor shall be responsible for all testing in accordance with the Technical Specifications per Section 5 of this document.
    - c. A representative of the Public Works Department or District Engineer shall be notified and be on-site when testing is to be conducted.
    - d. Testing reports shall be submitted to City and District weekly or more frequently as required for review. Areas with failed tests shall be corrected and retested.
    - e. Failure to have improvements tested as they are constructed may be cause for work stoppage or rejection by City and District.
    - f. City and District have the option to conduct independent testing at their discretion.
  2. District Projects
    - a. The Contractor shall select, hire, and pay a City-approved qualified testing firm.
    - b. Contractor shall be responsible for coordinating all testing and ensuring it is conducted in accordance with the Technical Specifications per Section 5 of this document.
    - c. Testing reports shall be submitted to City and District weekly or more frequently as required for review. Areas with failed tests shall be corrected and retested.
    - d. Failure to have improvements tested as they are constructed may be cause for work stoppage or rejection by City and District.
    - e. City and District have the option to conduct independent testing at their discretion.
- J. Safety
1. Contractor is solely responsible for jobsite safety.
  2. Contractor shall comply with all local, state, and federal rules and regulations regarding jobsite safety.
  3. City and District or its authorized representatives shall have the authority to shut down a job when unsafe working conditions are found.

#### **4.04 Miscellaneous**

A. Enforcement

1. Violators of the regulations as set forth in the Harrisville City Standards for work in the Public Way shall be subject to the provisions as set forth in the current City Code.

B. Guarantees

1. City's and District's Protective Liability Insurance: The permittee shall indemnify and hold the City and District harmless from and against any and all liability, damages, claims, demands, costs and expenses of whatsoever nature, including court costs and counsel fees, arising from or growing out of any injury to or death of any person or persons, whomsoever, or for loss of or damage to any property whatsoever, (including loss or damage to the tools, plant, or equipment of the permittee) resulting directly or indirectly from the carrying on of the work herein specified.
2. Bonding: Bonding as required by Harrisville City Code, Ordinance, and current rate structure.

## SECTION 5 TECHNICAL SPECIFICATIONS

### 5.01 Technical Specifications for Four-Mile Special Service District

- A. Adoption of Divisions 01 through 34 of the Manual of Standard Specifications, as published by Utah LTAP Center, Utah State University, Logan, Utah, current edition, with all published amendments. (Commonly known as the *APWA Specifications*)
- B. Modifications and Additions to Manual of Standard Specifications found in the Harrisville City Standards and Specification.

### 5.02 Order of Precedence

- A. Approved project-specific specifications (when applicable)
- B. Modifications and Additions to Manual of Standard Specifications (APWA)
- C. Manual of Standard Specifications (APWA), current edition, with all published amendments

## **SECTION 6      STANDARD DRAWINGS, PLANS, AND DETAILS**

### **6.01      Standard Drawings, Plans, and Details for Fourmile Special Service District**

- A. Four-Mile Special Service District Standard Drawings, current edition (See Appendix A)
- B. Adoption of Manual of Standard Plans, published by Utah LTAP Center, Utah State University, Logan, Utah, current edition, with all published amendments. (Commonly known as the *APWA Plans*)

### **6.02      Order of Precedence**

- A. Approved project-specific drawings and details (when applicable)
- B. Four-Mile Special Service District Standard Drawings, current edition
- C. Manual of Standard Plans (APWA), current edition, with all published amendments, when not covered by one of the aforementioned items

## **APPENDIX A – FOUR-MILE SPECIAL SERVICE DISTRICT STANDARD DRAWINGS**



# FOUR MILE SPECIAL SERVICE DISTRICT STANDARD DRAWINGS

**SUBMITTED & RECOMMENDED**

 8/15/2023

SERVICE DISTRICT ENGINEER

SEAL

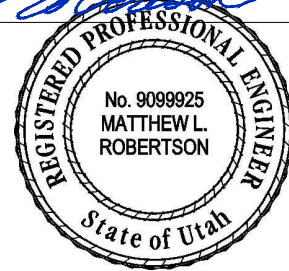

**APPROVAL**

BOARD CHAIRPERSON  
FOUR MILE SPECIAL SERVICE DISTRICT

DATE

SERVICE DISTRICT PUBLIC WORKS DIRECTOR

DATE

DATE

ATTEST, CITY RECORDER

DATE

## **INDEX OF DRAWINGS** (5 Sheets)

SECONDARY WATER (IRRIGATION) SYSTEM STANDARDS  
SW1....TYPICAL SECONDARY WATER SERVICE LATERALS  
SW2....SECONDARY WATER SERVICE LATERAL DETAILS  
SW3....SECONDARY WATER AIR/VAC, DRAIN, AND  
GATE VALVE DETAILS  
SW4....SECONDARY WATER PRE-PACKAGED PUMP  
STATION DETAILS  
SW5....UTILITY TRENCH, THRUST BLOCK, WATERLINE  
LOOP, AND CONCRETE COLLAR DETAILS

ALL LANDSCAPING AND OTHER IMPROVEMENTS ARE TO BE RESTORED AFTER CONSTRUCTION.

PROVIDE A SECONDARY WATER AIR RELIEF OR BLOW-OFF (AS DETERMINED BY THE SERVICE DISTRICT ENGINEER) ON ALL DEAD-END MAINS. SEE SHEET SW3

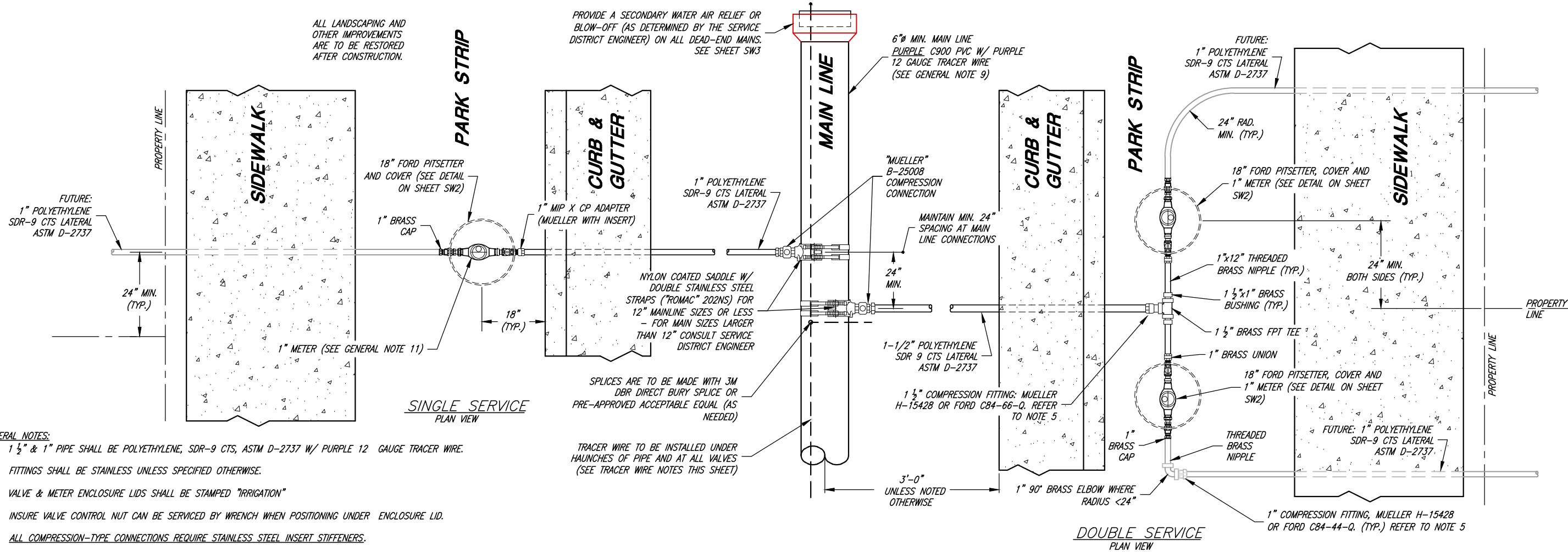

**GENERAL NOTES:**

1. 1 1/2" & 1" PIPE SHALL BE POLYETHYLENE, SDR-9 CTS, ASTM D-2737 W/ PURPLE 12 GAUGE TRACER WIRE.
2. FITTINGS SHALL BE STAINLESS UNLESS SPECIFIED OTHERWISE.
3. VALVE & METER ENCLOSURE LIDS SHALL BE STAMPED "IRRIGATION"
4. INSURE VALVE CONTROL NUT CAN BE SERVICED BY WRENCH WHEN POSITIONING UNDER ENCLOSURE LID.
5. ALL COMPRESSION-TYPE CONNECTIONS REQUIRE STAINLESS STEEL INSERT STIFFENERS.
6. THE TUBING SHOULD BE INSERTED INTO THE FITTING SO THAT THE END OF THE TUBING IS WELL PAST THE RUBBER GASKET AND AT LEAST 1/8" FROM THE BOTTOM OF THE SOCKET.
7. SERVICE LINES ARE TO BE TAPPED LEVEL.
8. CONCRETE COLLARS SHALL BE SQUARE.
9. ALL MAIN LINES ARE TO BE MIN. 6" PURPLE C900 W/ PURPLE LOCATOR TAPE & PURPLE 12 GAUGE TRACER WIRE & INSTALLED TO LIMITS OF SUBDIVISION (OR STREET).

**C900 PIPE: PURPLE**

12" OR SMALLER Ø PIPE SHALL BE C900 DR-14  
14" OR LARGER Ø PIPE SHALL BE C900 DR-18

10. "BLUE" BOLTS AND NUTS ARE REQUIRED BY THE SERVICE DISTRICT

11. ALL SUPPLIES, LABOR, EQUIPMENT, ETC. SHALL BE SUPPLIED BY THE DEVELOPER/CONTRACTOR EXCEPT THE SECONDARY WATER METERS. THE SECONDARY WATER METERS SHALL BE PAID FOR BY THE DEVELOPER/CONTRACTOR. THE SERVICE DISTRICT WILL SUPPLY AND SET ALL SECONDARY WATER METERS AT TIME OF HOME CONSTRUCTION.

**TRACER WIRE NOTES:**

- A1. ALL SECONDARY WATER LINES SHALL HAVE A MINIMUM 12 GA. INSULATED TRACER WIRE INSTALLED UNDER THE HAUNCHES OF THE PIPE PRIOR TO BACKFILLING.
- A2. TRACER WIRES SHALL TERMINATE AT ALL METERS. AT SERVICE SADDLES AND TAPPING SLEEVES, THE TRACER WIRE SHALL NOT BE ALLOWED TO BE PLACED BETWEEN THE SADDLE AND THE PIPE. A GROUNDING ROD SHALL BE INSTALLED AT ALL TRACER SYSTEM TERMINAL POINTS.
- A3. TRACER WIRE SHALL BE COPPER WIRE WITH PURPLE INSULATION RATED FOR DIRECT BURIAL. ALL WIRE CONNECTORS SHALL BE 3M DBR DIRECT BURY SPLICE OR PRE-APPROVED ACCEPTABLE EQUAL AND SHALL BE WATERTIGHT TO PROVIDE ELECTRICAL CONTINUITY.
- A4. ALL TRACER WIRE SHALL BE TESTED FOR CONTINUITY IN THE PRESENCE OF THE SERVICE DISTRICT PUBLIC WORKS INSPECTOR PRIOR TO ASPHALT PLACEMENT. ANY TRACER WIRE FOUND NOT TO BE CONTINUOUS AFTER TESTING SHALL BE REPAIRED OR REPLACED BY THE CONTRACTOR PRIOR TO ASPHALT PLACEMENT.

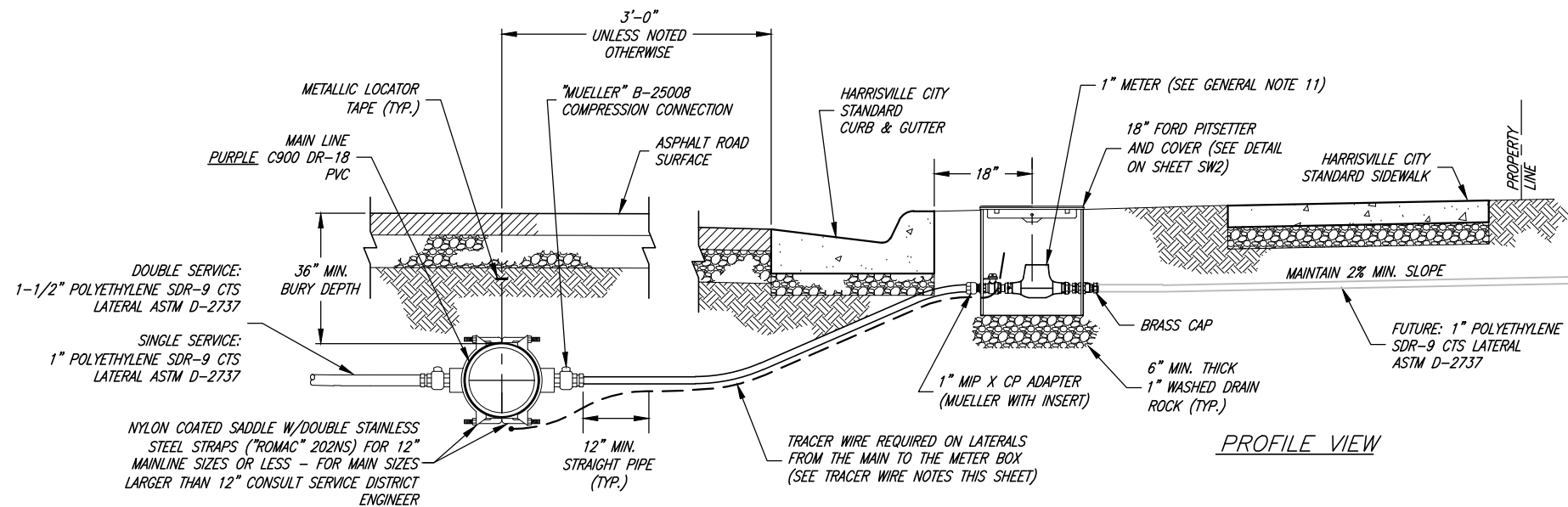

**CURBED ROAD SECONDARY WATER SERVICE LATERAL**



PROJECT ENGINEER  
DATE: 8/15/2023

REV.	DATE	APPR.

SCALE:  
N.T.S.



**CONSULTING ENGINEERS**  
6080 Fashion Point Drive  
South Ogden, Utah 84403 (801) 476-9767  
www.jonescivil.com

**FOUR MILE SPECIAL SERVICE DISTRICT**  
STANDARD DRAWINGS

**TYPICAL SECONDARY WATER SERVICE LATERALS**

SHEET:  
**SW1**  
OF 1 SHEETS  
0

**"FORD" PITSETTER**  
**PK488-18-95059-017-NL**

**"DFW" LID**  
**DFW18FD-5MBAF**

SUBMITTAL INFORMATION			
"K" Plastic Pitsetter - (PK488-18-95059-017-NL style)			
SINGLE SETTING FOR 1" METER			
MALE IRON PIPE THREAD INLET AND OUTLET			
FLAT LID-STRAIGHT BALL VALVE INLET BY ADJUSTABLE STRAIGHT METER COUPLING OUTLET			

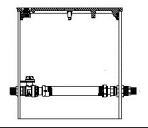

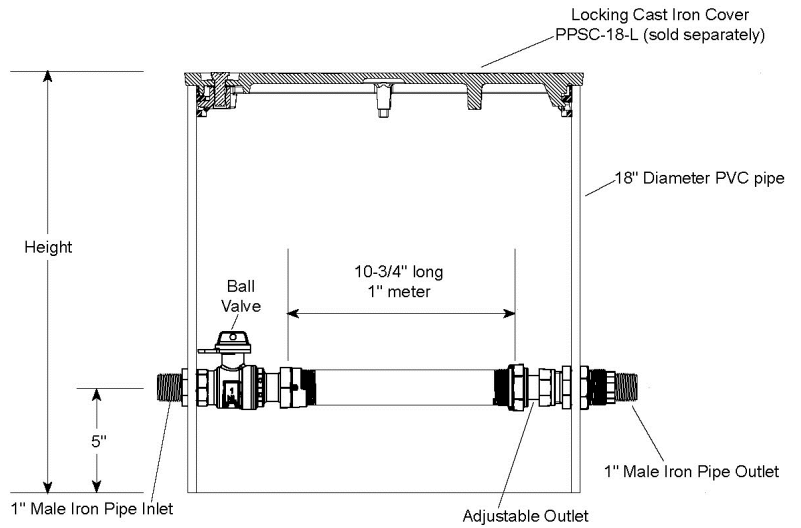

PIT DIAMETER	HEIGHT	CATALOG NUMBER	✓ SUBMITTED ITEM
18"	20"	PK488-18-95059-017-NL	✓

**FEATURES**

- All brass that comes in contact with potable water conforms to AWWA Standard C800 (ASTM B584, UNS C89833)
- The product has the letters "NL" cast into the main body for lead-free identification
- Brass components that do not come in contact with potable water conform to AWWA Standard C800 (ASTM B62 and ASTM B584, UNS C83600, 85-5-5-5)
- Easy installation - simply make inlet and outlet connections, install meter and cover
- Locking cast iron cover (Catalog Number PPSC-18-L) not included, sold separately

The Ford Meter Box Company considers the information in this submittal form to be correct at the time of publication. Item and option availability, including specifications, are subject to change without notice. Please verify that your product information is current. Our standard warranty applies.



**The Ford Meter Box Company, Inc.**  
 P.O. Box 443, Wabash, Indiana U.S.A. 46992-0443  
 Phone: 260-563-3171 / Fax: 800-826-3487  
 Overseas Fax: 260-563-0167  
 www.fordmeterbox.com

Submitted By:

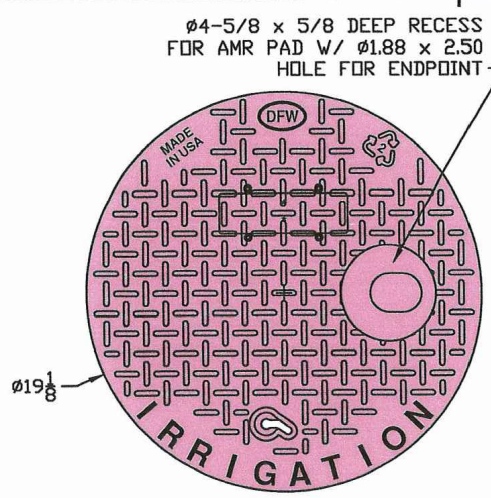

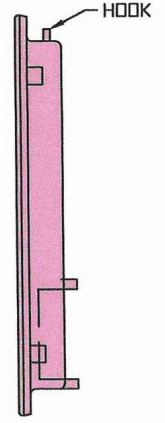

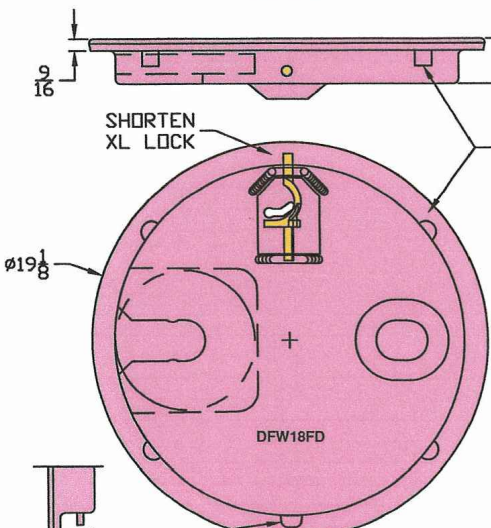

LID KEY	
5	PURPLE COLOR - PMS 522C
M	MAGNET
B	BRASS LOCK
A	AMR SLIDE MOUNT
F	5/8" DEEP RECESS KNOCKOUT
IRRIG	IRRIGATION ENGRAVING

**NOTES**

1) DIM'S ± 1/8" U.N.O.  
 2) LID MATERIAL: HDPE

DFW PLASTICS, INC. ENGAGES IN ONGOING RESEARCH AND DEVELOPMENT TO IMPROVE AND ENHANCE ITS PRODUCTS. THEREFORE, DFW PLASTICS, INC. RESERVES THE RIGHT TO CHANGE PRODUCT OR SYSTEM SPECIFICATIONS WITHOUT NOTICE.



**DFW PLASTICS, INC.**  
 PO BOX 648  
 BEDFORD, TEXAS 76095  
 (817) 439-3600  
 (817) 439-3700 (f)  
 www.dfwplasticsinc.com

DFW18FD-5MBAF IRRIG-LID

CREATED: 11/13/2017  
 UPDATED: 11/13/2017  
 ACCEPTED: JMc  
 DRAWN BY: RMc  
 PLOT SCALE: 1:6

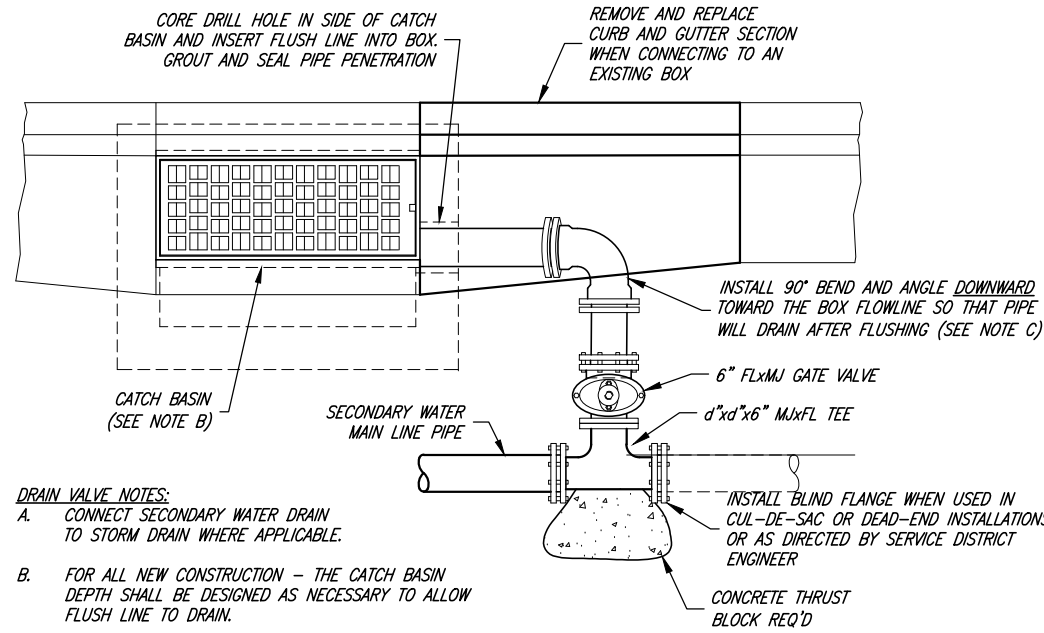

- DRAIN VALVE NOTES:**
- CONNECT SECONDARY WATER DRAIN TO STORM DRAIN WHERE APPLICABLE.
  - FOR ALL NEW CONSTRUCTION - THE CATCH BASIN DEPTH SHALL BE DESIGNED AS NECESSARY TO ALLOW FLUSH LINE TO DRAIN.
  - WHEN CONNECTING TO AN EXISTING CATCH BASIN AND THE IRRIGATION LINE IS DEEPER THAN THE EXISTING BOX FLOWLINE, OR IN AREAS WHERE A STORM DRAIN SYSTEM IS NOT AVAILABLE FOR CONNECTION, CONSTRUCT CATCH BASIN WITH AN OPEN BOTTOM/SUMP. SEE DETAIL THIS SHEET (REQUIRES APPROVAL BY THE SERVICE DISTRICT ENGINEER PRIOR TO CONSTRUCTION)

**TYPICAL DRAIN VALVE  
DETAIL**

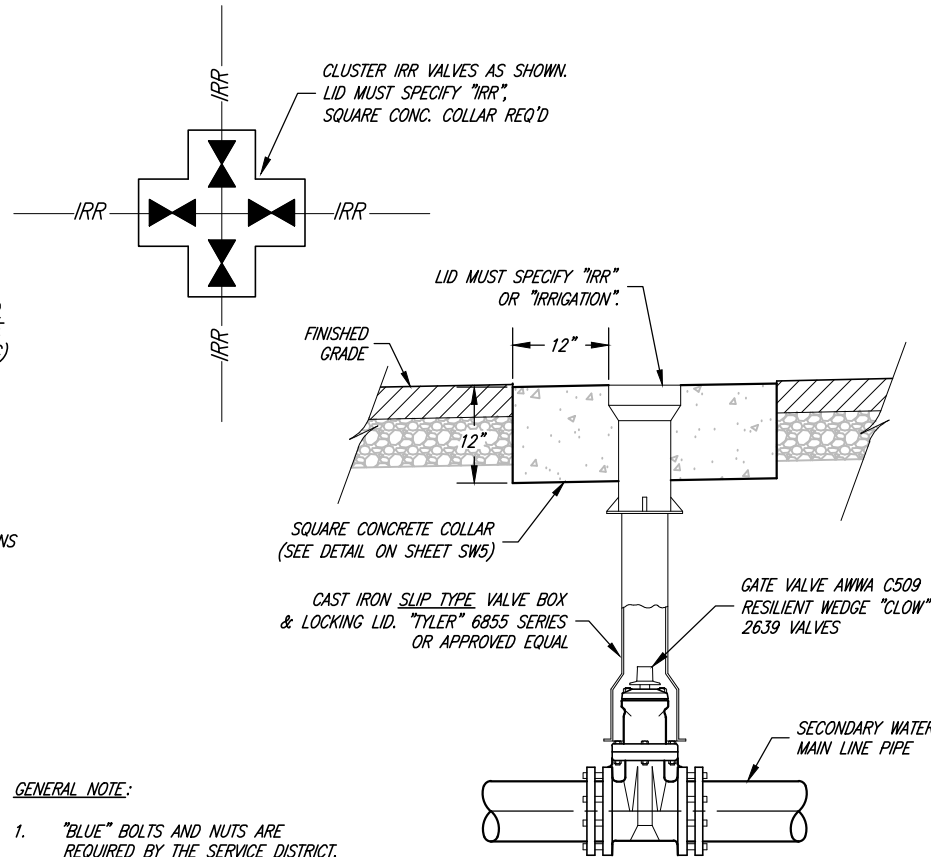

- GENERAL NOTE:**
- "BLUE" BOLTS AND NUTS ARE REQUIRED BY THE SERVICE DISTRICT.

**GATE VALVE DETAIL**

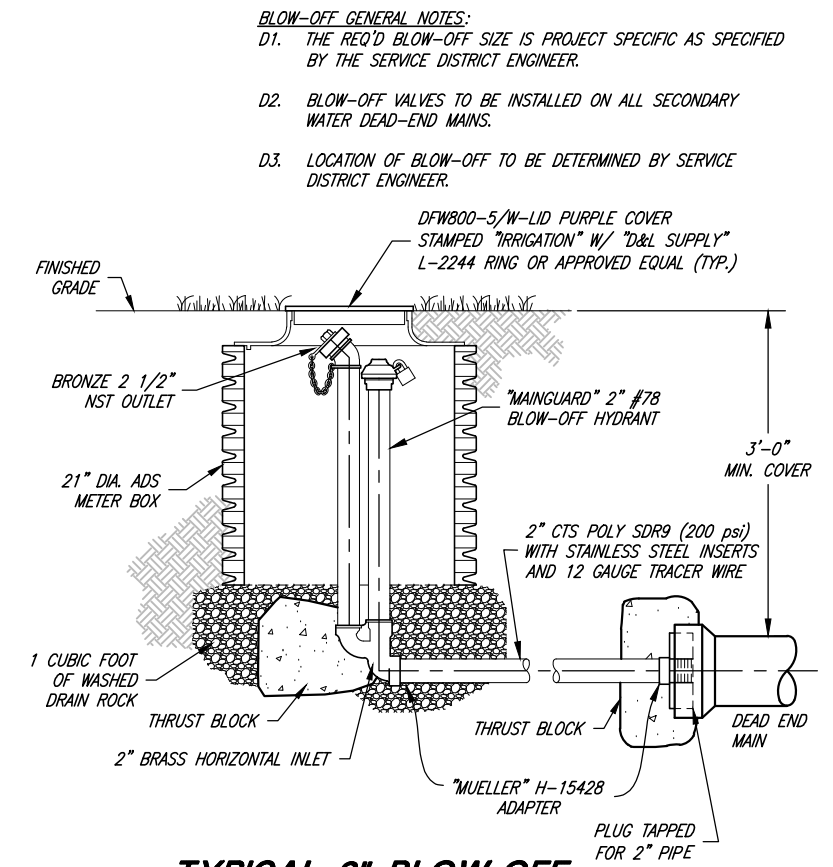

**TYPICAL 2" BLOW-OFF  
(FLUSH) VALVE CONNECTION**

SECONDARY WATER MAINS

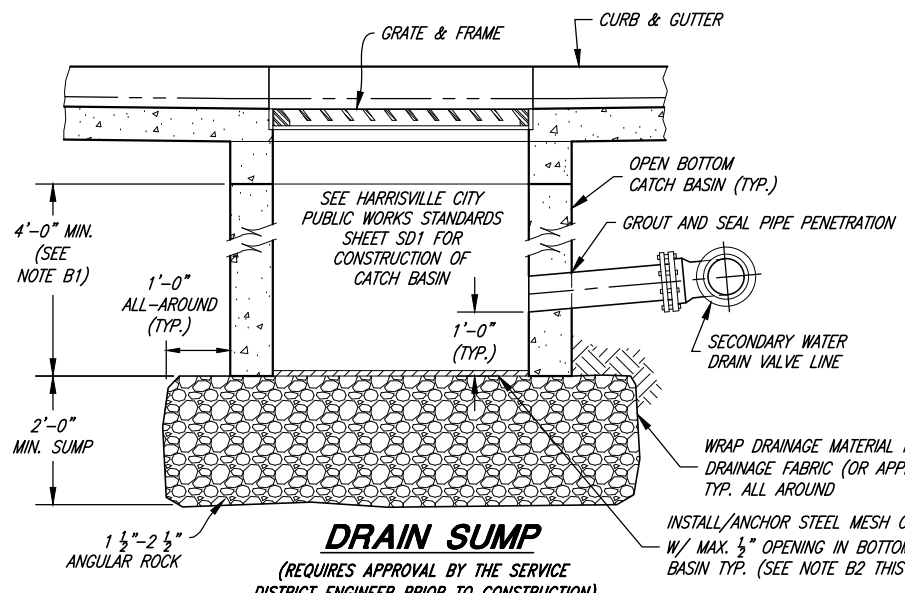

**DRAIN SUMP**

(REQUIRES APPROVAL BY THE SERVICE DISTRICT ENGINEER PRIOR TO CONSTRUCTION)

- SUMP DRAIN NOTES:**
- THE DEPTH OF THE DRAINAGE BOX SHALL BE MODIFIED AS NECESSARY TO ALLOW FLUSH LINE TO DRAIN.
  - MESH/GEOGRID DIMENSIONS: NO LESS THAN 1" LESS THAN INNER DIMENSIONS, ALL SIDES.

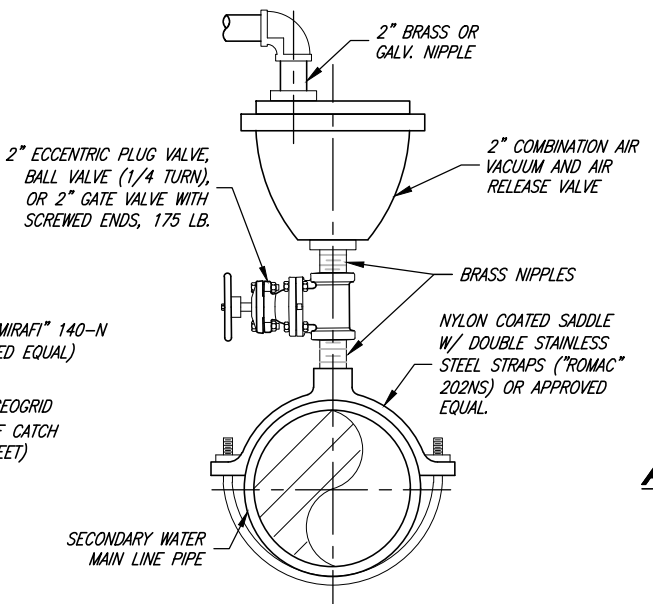

**AIR-VACUUM AND  
AIR-RELEASE VALVE**

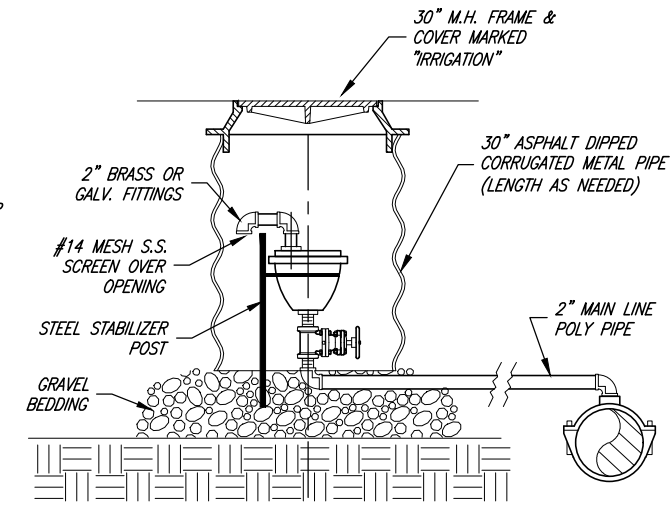

**AIR VACUUM & AIR RELEASE VALVE  
PARK STRIP OR SHOULDER  
INSTALLATION**

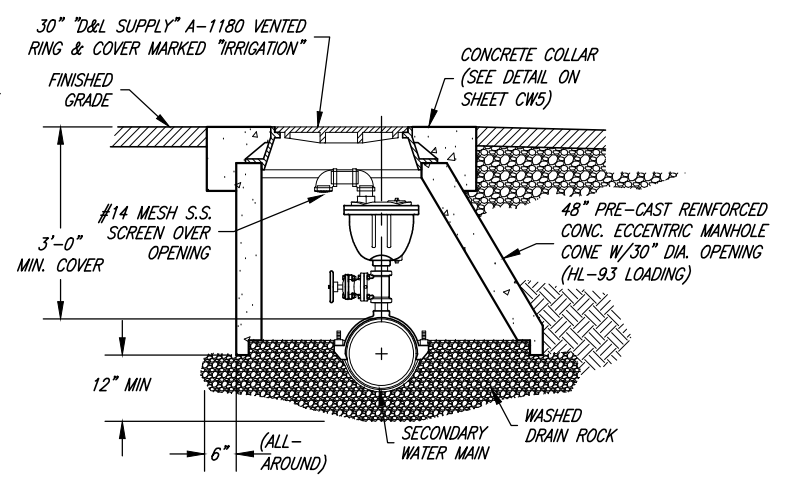

**AIR VACUUM & AIR RELEASE VALVE  
STREET INSTALLATION**

- AIR VACUUM & AIR RELEASE VALVE NOTES:**
- WHERE APPLICABLE, AIR-VACUUM RELIEF VALVE ASSEMBLY SIZE MAY NEED TO BE INCREASED. THIS IS A CASE BY CASE ITEM DETERMINED BY THE SERVICE DISTRICT ENGINEER.
  - RAISE ALL MANHOLES TO FINISHED GRADE OF STREET FOLLOWING PAVING WITH A CONCRETE COLLAR. (SEE DETAIL ON SHEET CW5)

REGISTERED PROFESSIONAL ENGINEER  
No. 9069925  
MATTHEW L. ROBERTSON  
State of Utah

PROJECT ENGINEER  
8/15/2023

REV.	DATE	APPR.

SCALE: N.T.S.

**J&A**  
JONES & ASSOCIATES

**CONSULTING ENGINEERS**  
6080 Fashion Point Drive  
South Ogden, Utah 84403 (801) 476-9767  
www.jonescivil.com

FOUR MILE SPECIAL SERVICE DISTRICT  
STANDARD DRAWINGS  
**SECONDARY WATER AIR/VAC, DRAIN,  
AND GATE VALVE DETAILS**

SHEET:  
**SW3**  
OF 1 SHEETS  
0

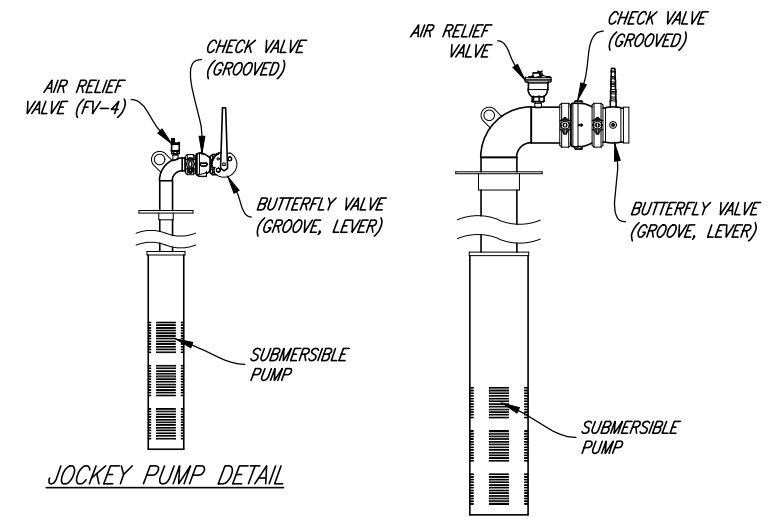
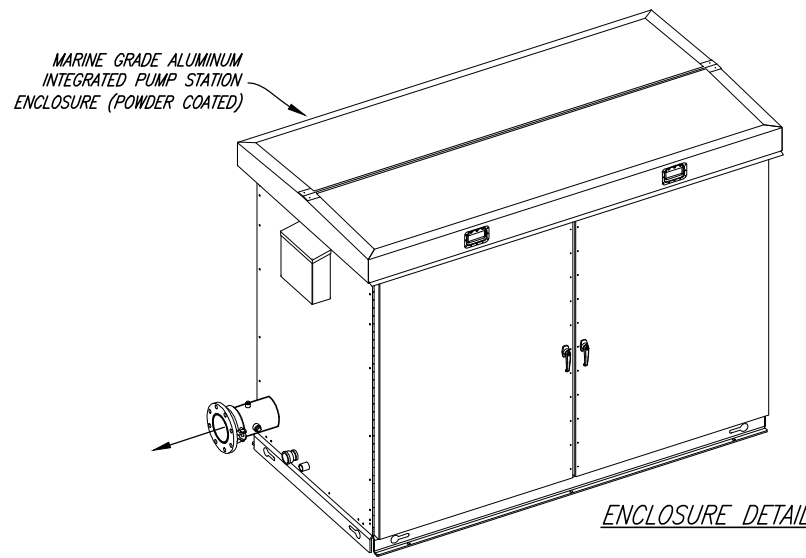
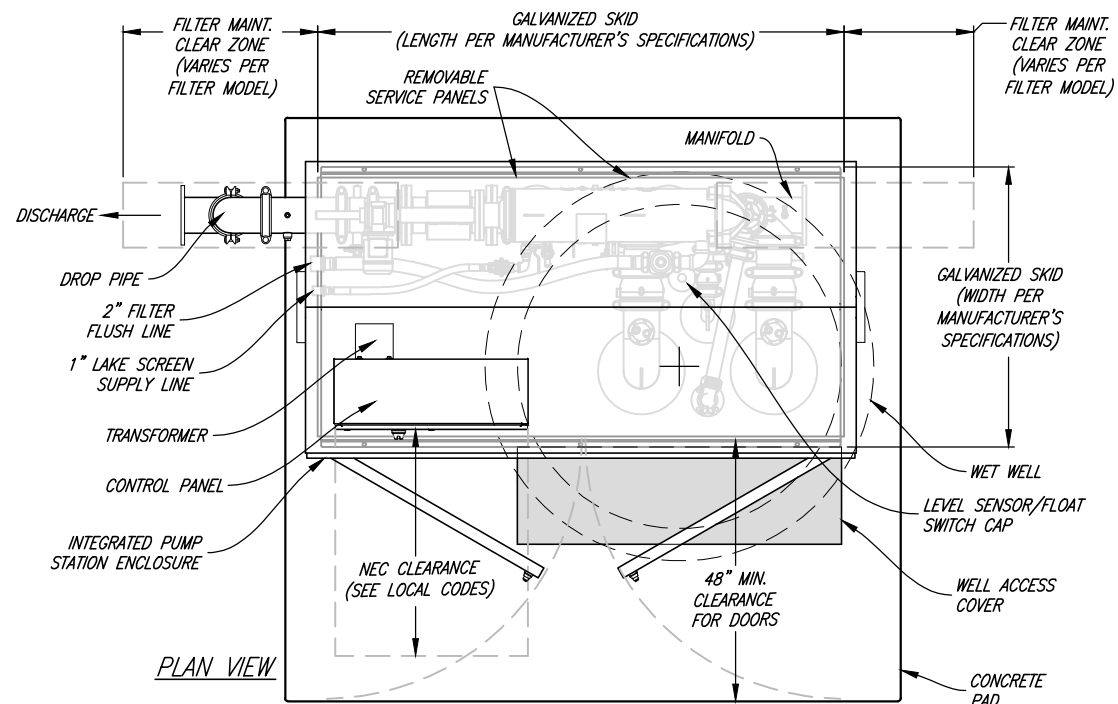

**PUMP STATION NOTES:**

- COORDINATE INSTALLATION OF POWER TRANSFORMER & POWER LINE W/ UP&L. SIZE & CONSTRUCT TRANSFORMER PAD PER UP&L. SPECS. TRANSFORMER TO BE SIZED FOR PUMPS & FILTER REQUIREMENTS.
- ALL ELECTRICAL FIXTURES, CONDUITS & FITTINGS TO BE NON-CORROSIVE MATERIAL-INTERIOR & EXTERIOR.
- ALL ELECTRICAL TO BE TO NEC COMMERCIAL CODES.
- ALL ELECTRICAL WIRING TO BE ENCLOSED IN CONDUIT.
- PUMP SYSTEM PIPING TO BE STAINLESS STEEL OR POWDER-COATED.
- IRRIGATION LINE IS TO HAVE 3'-0" MINIMUM COVER.
- ALL EXPOSED PIPING, VALVES, FITTINGS, AND OTHER MISC. PARTS OF THE PIPING SYSTEM OUTSIDE OF THE ENCLOSURE SHALL BE PAINTED W/1 COAT OF PRIMER AND 2 COATS OF ACRYLIC ENAMEL PAINT (PURPLE COLOR TO BE APPROVED BY THE SERVICE DISTRICT)
- ALL D.I.P. IN CONTACT W/ EARTH IS TO BE POLYETHYLENE ENCASED.
- SUBMIT SITE PLAN DESIGN TO THE SERVICE DISTRICT FOR WRITTEN APPROVAL PRIOR TO CONSTRUCTION. PROPERTY FENCE TO BE 6' HIGH CHAIN LINK W/ MINIMUM 12' WIDE ACCESS GATE FOR PUMP STATION MAINTENANCE.
- "AMIAD" FILTER NOTES:
  - SCREEN TO BE 200 MICRON
  - CONTROL TO BE STAINLESS STEEL
  - FILTER LID TO BE EPOXY COATED STEEL
  - CLEANING MECHANISM TO BE STAINLESS STEEL
  - EXHAUST VALVE TO BE EPOXY COATED CAST IRON.

**GENERAL NOTES:**

- THIS DRAWING AND ALL INFORMATION CONTAINED HEREIN IS FOR THE SOLE PURPOSE OF A DESIGN CONCEPT AND IS NOT FOR FABRICATION. CONTACT "PPS" DIRECTLY FOR THE DESIGN, SIZING, AND ALL PUMP STATION CONSTRUCTION RELATED DRAWINGS AS REQUIRED FOR THE PROJECT SPECIFIC SECONDARY SYSTEM SIZING AND PUMPING NEEDS.
- THE ENGINEER'S STAMP AFFIXED HERETO IS ONLY FOR THE PURPOSE OF IDENTIFYING THIS PRODUCT AS THE SERVICE DISTRICT STANDARD.
- CHANGES TO THIS DETAIL WILL BE MADE BY THE MANUFACTURER AT THEIR DISCRETION OR UNDER THE DIRECTION OF THE SERVICE DISTRICT ENGINEER OR PUBLIC WORKS DEPARTMENT.
- CONCRETE SLAB AND WET WELL DETAILS TO BE PROVIDED BY THE DEVELOPER/CONTRACTOR AND APPROVED BY THE SERVICE DISTRICT ENGINEER PRIOR TO CONSTRUCTION/INSTALLATION.

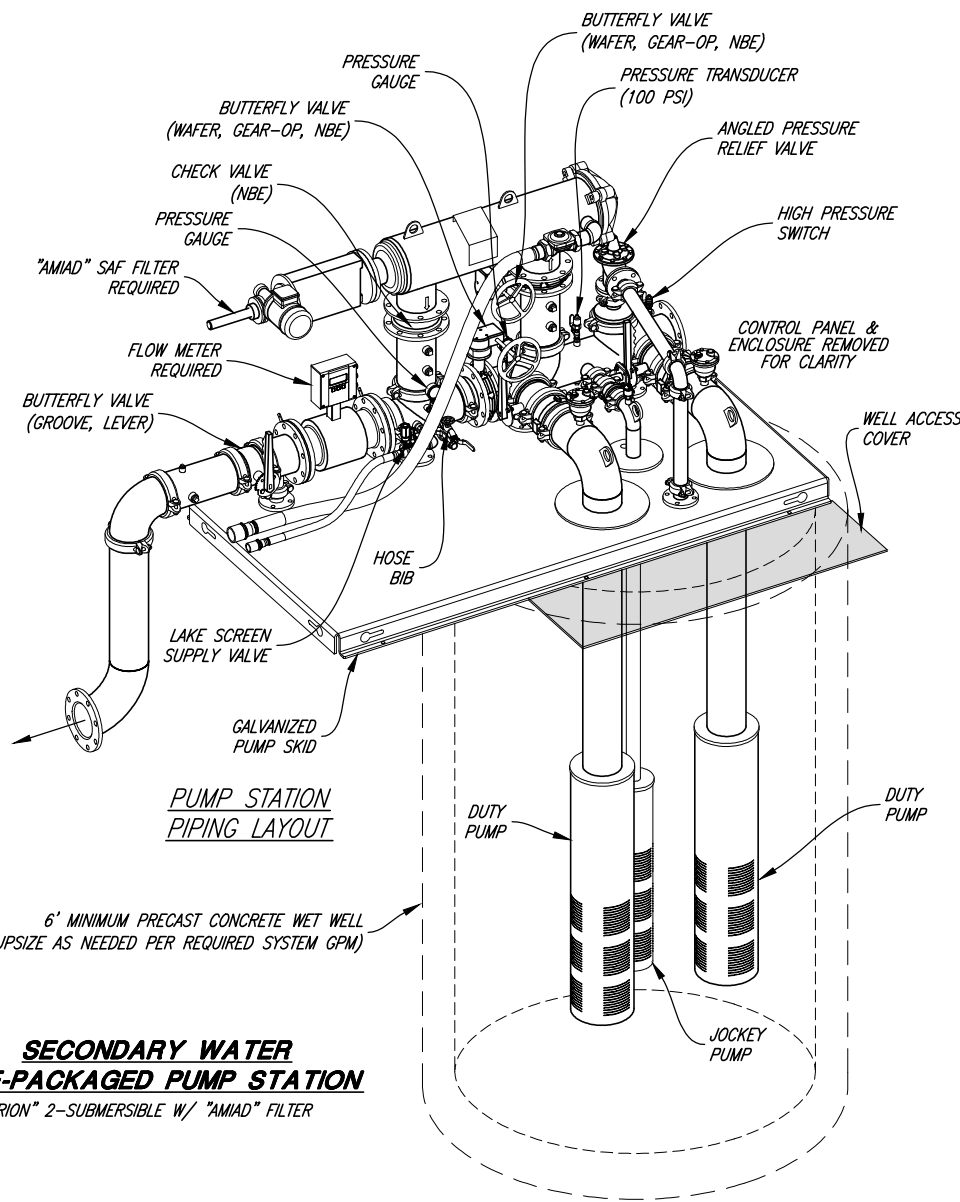
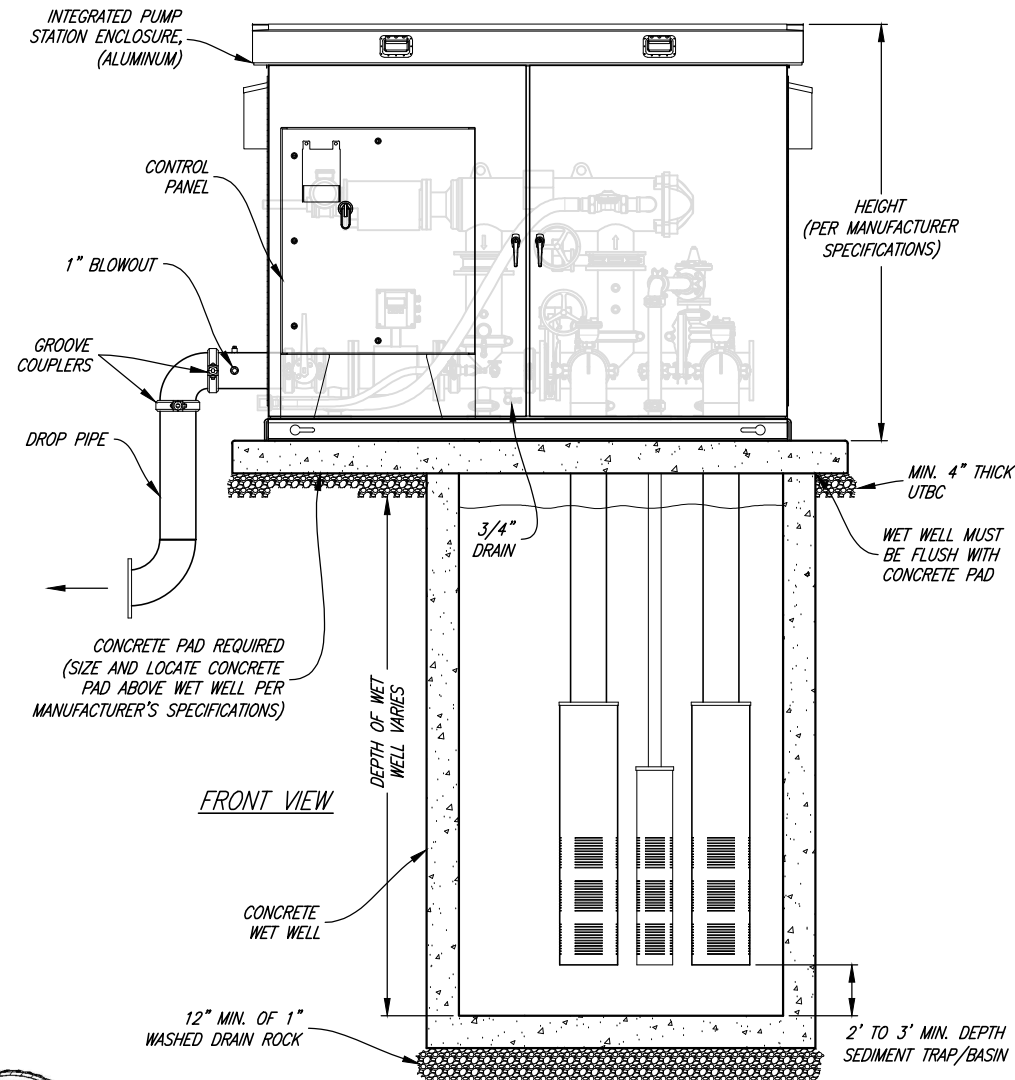

**SECONDARY WATER PRE-PACKAGED PUMP STATION**  
 "ORION" 2-SUBMERSIBLE W/ "AMIAD" FILTER

<b>ORION SERIES</b>	
<b>"PPS" PRECISION PUMPING SYSTEMS</b>	
<b>PRE-PACKAGED PUMP SYSTEM</b>	
DESIGN FLOW RATE: 150 - 1,000 GPM	
OPERATING PRESSURE: UP TO 150 PSI	
MINIMUM POWER: 240 VOLT / 3 PHASE	
HORSEPOWER: 10-40+ HP DEPENDING ON SYSTEM TYPE	
NON-POTABLE	SCALE: NTS (DO NOT SCALE DRAWING)



PROJECT ENGINEER		SCALE:
DATE: 8/15/2023		N.T.S.
REV.	DATE	APPR.



**CONSULTING ENGINEERS**  
 6080 Fashion Point Drive  
 South Ogden, Utah 84403 (801) 476-9767  
 www.jonescivil.com

**FOUR MILE SPECIAL SERVICE DISTRICT**  
**STANDARD DRAWINGS**  
**SECONDARY WATER PRE-PACKAGED PUMP STATION DETAILS**

SHEET:  
**SW4**  
 OF 1 SHEETS  
 0

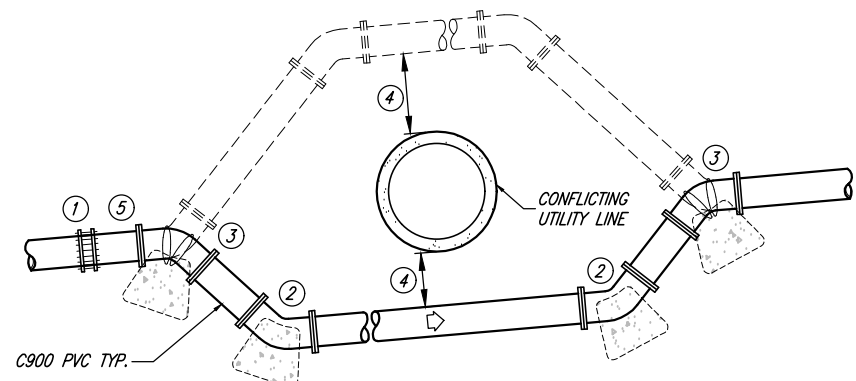

**TYPICAL WATERLINE LOOP**

- ① TRANSITION COUPLING; "ROMAC" ALPHA, "ROMAC" MACRO, OR APPROVED EQUAL.
- ② MJ 45° BEND W/RETAINER GLANDS.
- ③ CONSTRUCT THRUST BLOCKS AT EACH 45° BEND W/(3) #6 REBAR SECURING BLOCK TO FITTING (EPOXY COATING).
- ④ MINIMUM OF 12" SEPARATION BETWEEN THE WATERLINE AND CONFLICTING UTILITY LINE TO BE CROSSED.
- ⑤ AN AIR/VACUUM RELIEF VALVE MAY BE REQUIRED ON A CASE BY CASE BASIS AS DIRECTED BY THE SERVICE DISTRICT ENGINEER.

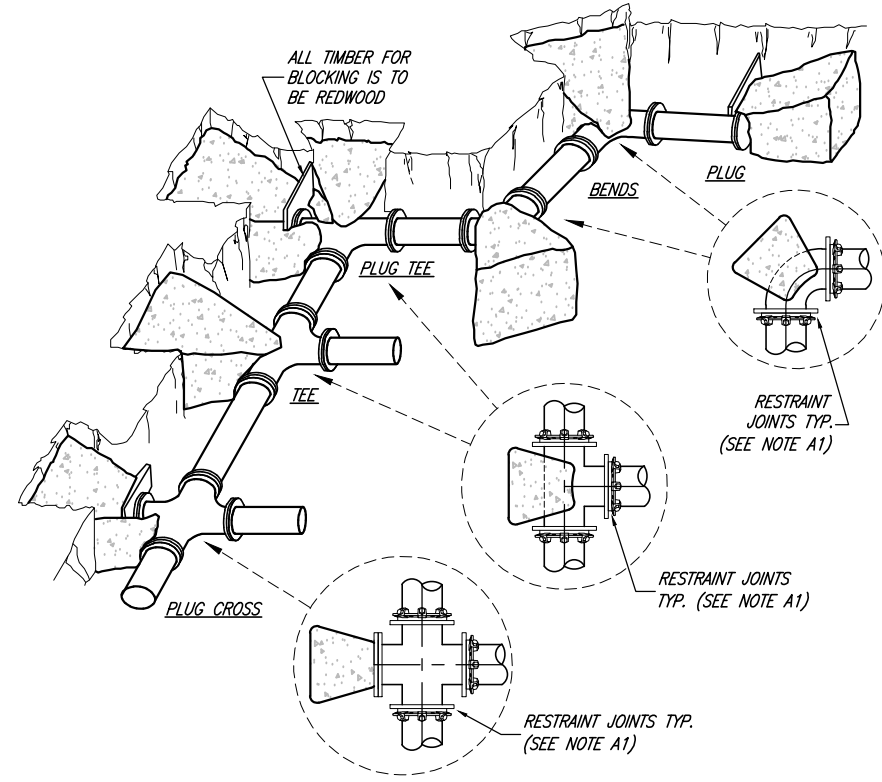

**TYPICAL RETAINER GLANDS & THRUST BLOCKING**

- GENERAL NOTES:**
- D1. "BLUE" BOLTS AND NUTS ARE REQUIRED BY THE SERVICE DISTRICT

THRUST PER PSI OF WATER PRESSURE AT VARIOUS FITTINGS

PIPE SIZE (IN.)	DEAD END OR TEE (LB.)	90° ELBOW (LB.)	45° ELBOW (LB.)	22-1/2° ELBOW (LB.)
4	19	27	15	7
6	39	55	30	15
8	67	94	51	26
10	109	154	84	43
12	155	218	119	61
14	210	296	161	82
16	272	383	209	106
18	351	494	269	137
20	434	611	333	169
24	623	878	487	244
30	947	1,332	722	377
36	1,356	1,905	1,032	542

- NOTES:**
- C1. IN USING THE ABOVE TABLE, USE THE MAXIMUM INTERNAL PRESSURE ANTICIPATED (I.E. HYDROSTATIC TEST PRESSURE, POSSIBLE SURGE PRESSURE DUE TO PUMP SHUT OFF, ETC.).
  - C2. SEE SOILS REPORT FOR BEARING STRENGTH OF SOIL. IN THE ABSENCE OF A SOILS REPORT, AN AVERAGE SOIL (SPADABLE MEDIUM CLAY) CAN BE ASSUMED TO HAVE A BEARING STRENGTH OF 2000 P.S.F.

**EXAMPLE:**  
 8-INCH 90° ELBOW, PRESSURE 200 LB./SQ. IN.  
 FROM TABLE: THRUST = 94 X 200 = 18,800 LB.  
 ASSUME BEARING STRENGTH = 2,000 LB./SQ. FT.

$\frac{18,800}{2,000} = 9.4 \text{ SQ. FT.}$  AREA OF BEARING REQUIRED FOR THRUST BLOCK

**PIPE RESTRAINT**

- A1. FOR NOMINAL PIPE DIAMETERS 6" AND GREATER, ALL BENDS, CROSSES, TEES, REDUCERS, AND VALVES SHALL BE INSTALLED WITH RESTRAINING JOINTS ("MEGA-LUG", "ALPHA" OR APPROVED EQUAL).
- A2. DESIGN SHALL ALSO BE REQUIRED TO ENSURE ADEQUATE RESTRAINT FOR PIPING JOINTS NEAR FITTINGS BASED ON PIPE DIAMETER AND PIPE PRESSURE.

**THRUST BLOCKING NOTES:**

- B1. CONCRETE SHALL NOT BE PLACED WITHIN 1-1/2" OF JOINTS AND BOLTS. COVER ALL METAL CONTACT AREAS WITH A POLY WRAP PRIOR TO CONCRETE PLACEMENT.
- B2. IN THE ABSENCE OF A SOILS REPORT, ALL THRUST BLOCKS SHALL BE SIZED ON THE BASIS OF A MAXIMUM LATERAL BEARING VALUE FOR 2000 P.S.F. AND A THRUST RESULTING FROM 200% OF THE WATER LINE STATIC LINE TEST.
- B3. THRUST BLOCKS ARE REQUIRED AT ALL BENDS OF 22-1/2° OR MORE. 11-1/4° BENDS SHALL HAVE RETAINER GLANDS.
- B4. CONCRETE SHALL HAVE A COMPRESSIVE STRENGTH OF NOT LESS THAN 3000 PSI IN 28 DAYS.

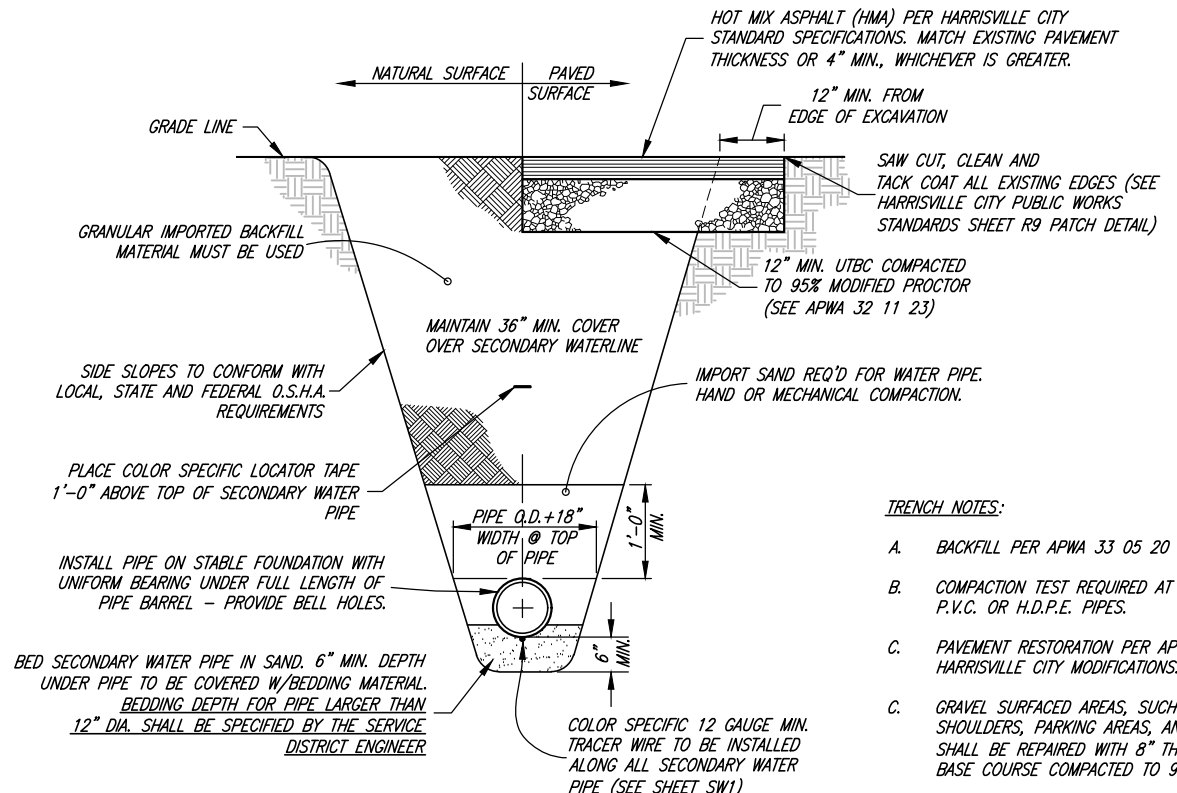

**TYPICAL TRENCH SECTION (SECONDARY WATER/IRRIGATION)**

- TRENCH NOTES:**
- A. BACKFILL PER APWA 33 05 20
  - B. COMPACTION TEST REQUIRED AT SPRING-LINE FOR ALL P.V.C. OR H.D.P.E. PIPES.
  - C. PAVEMENT RESTORATION PER APWA 33 05 25 AND HARRISVILLE CITY MODIFICATIONS.
  - C. GRAVEL SURFACED AREAS, SUCH AS ROADS AND SHOULDERS, PARKING AREAS, AND UNPAVED DRIVEWAYS, SHALL BE REPAIRED WITH 8" THICK (MIN.) 1" UNTREATED BASE COURSE COMPACTED TO 95% MODIFIED PROCTOR.
  - D. WATER & SEWER LINES, INCLUDING SERVICE LINES, SHALL NOT BE INSTALLED IN THE SAME TRENCH.

**CONCRETE COLLAR NOTES:**

- C1. LID FOR SECONDARY WATER TO BE STAMPED "IRR" OR "IRRIGATION".
- C2. ALL CONCRETE COLLARS TO BE INSTALLED WITHIN 14 DAYS AFTER PAVING.
- C3. COLLARS AROUND IRRIGATION VALVES AND MANHOLES ARE TO BE SQUARE. (COLLARS AROUND CULINARY WATER VALVES AND MANHOLES ARE TO BE ROUND)
- C4. FIBER MESH SHALL BE ADDED TO ALL CONCRETE COLLARS (1 lb PER CUBIC YARD).
- C5. GRADE RINGS:
  - a. NO MORE THAN 12" DEPTH OF GRADE RINGS TO BE ALLOWED ON ANY MANHOLE
  - b. NO MORE THAN 3 (EA) GRADE RINGS TO BE INSTALLED ON ANY MANHOLE
  - c. NO MORE THAN 2 (EA) GRADE RINGS WITH THE "WHIRLYGIG" MANHOLE RISER/SYSTEM TO BE INSTALLED ON ANY MANHOLE

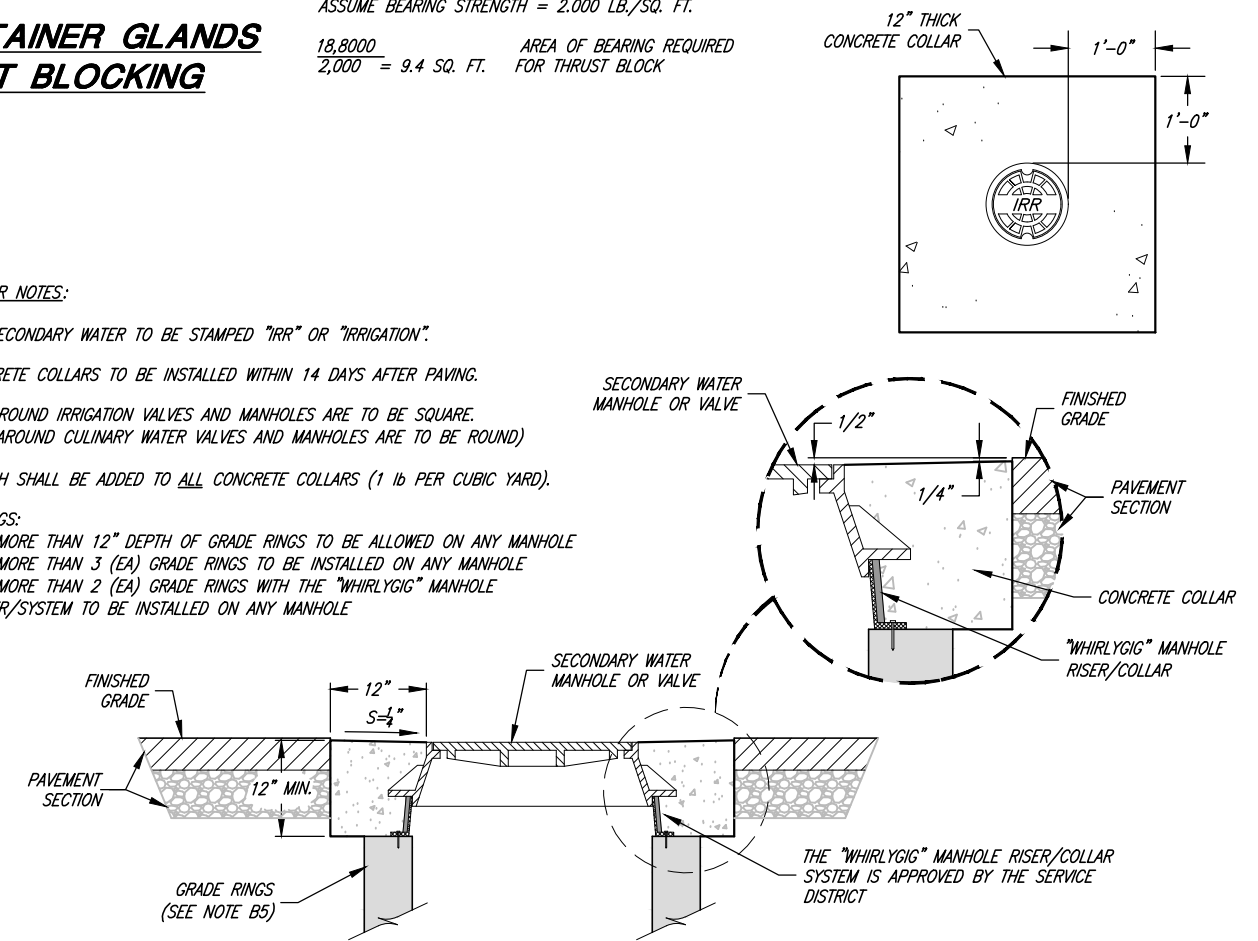

**CONCRETE COLLAR DETAIL**



PROJECT ENGINEER	DATE	REV.	DATE	APPR.
Matthew L. Robertson	8/15/2023			

SCALE: N.T.S.

**JJA CONSULTING ENGINEERS**  
 6080 Fashion Point Drive  
 South Ogden, Utah 84403 (801) 476-9767  
 www.jonescivil.com

FOUR MILE SPECIAL SERVICE DISTRICT  
 STANDARD DRAWINGS  
**UTILITY TRENCH, THRUST BLOCK, WATERLINE LOOP, AND CONCRETE COLLAR DETAILS**